

01-84 Series

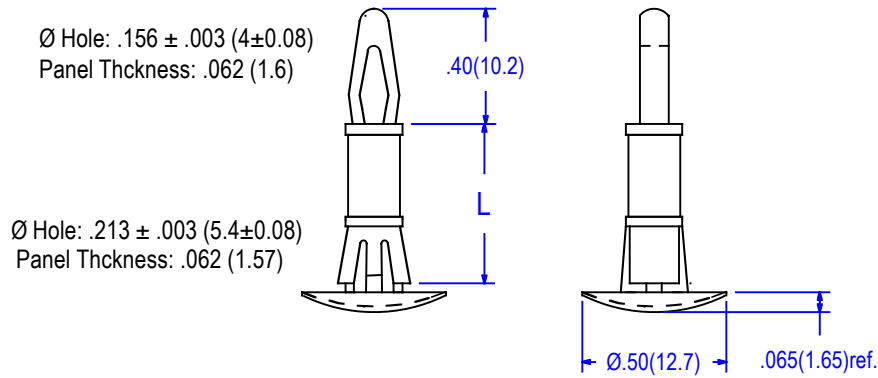

ITEM NO.	L	
	In. ±.015	mm. ± 0.4
01-84-30	.187	4.8
01-84-40	.250	6.4
01-84-60	.375	9.5
01-84-80	.500	12.7
01-84-100	.625	15.9

PACKAGING : 1000 PER BAG

UL 94V-O MATERIAL AVAILABLE UPON REQUEST
TO ORDER ADD SUFFIX "X" TO ITEM NUMBER

MATERIAL	NYLON 66
UL RATING	94V-2
UL FILE NO.	E41938
COLOR	NATURAL
RoHS COMPLIANCE	YES
TEMPERATURE RANGE (REF.)	-40 to 185°F (-40 to 85°C)
MR NUMBER	12

				BY	DATE	Title PCB SUPPORT, reverse mount	
						Part No. 01-84 series	Issue 0
						DIMS. Inches (mm) Tolerance (unless noted) .xx = ±.010 .xxx = .005	0
						Drwg. type Catalog	12/02/18
						File No. 01-84series	
No	Revision	Date	Init.	ALL ELECTRONICS HARDWARE INC. 2642 CORPORATE PARKWAY ALGONQUIN, ILLINOIS . 60102 1-800-778-7234			